

### RETROFIT RIGID TROUGH SHAFT FOR REPLACING THE INTER-AXLE DIFFERENTIAL IN FRMP-13/16-S AXLES

The inter-axle differential can be converted to a rigid trough shaft construction in such applications where the conventional inter-axle differentials are subject to excessive stress.

When converting the inter-axle to a through shaft construction the items mentioned in Picture No. 1. have to be removed. In Picture No. 2. there are the new items to be installed.

Please use the Maintenance Manual for MP-330 differential carrier assembly as guideline.

Note! This conversion can only be made to axles with final ratios 4.92:1 or higher.

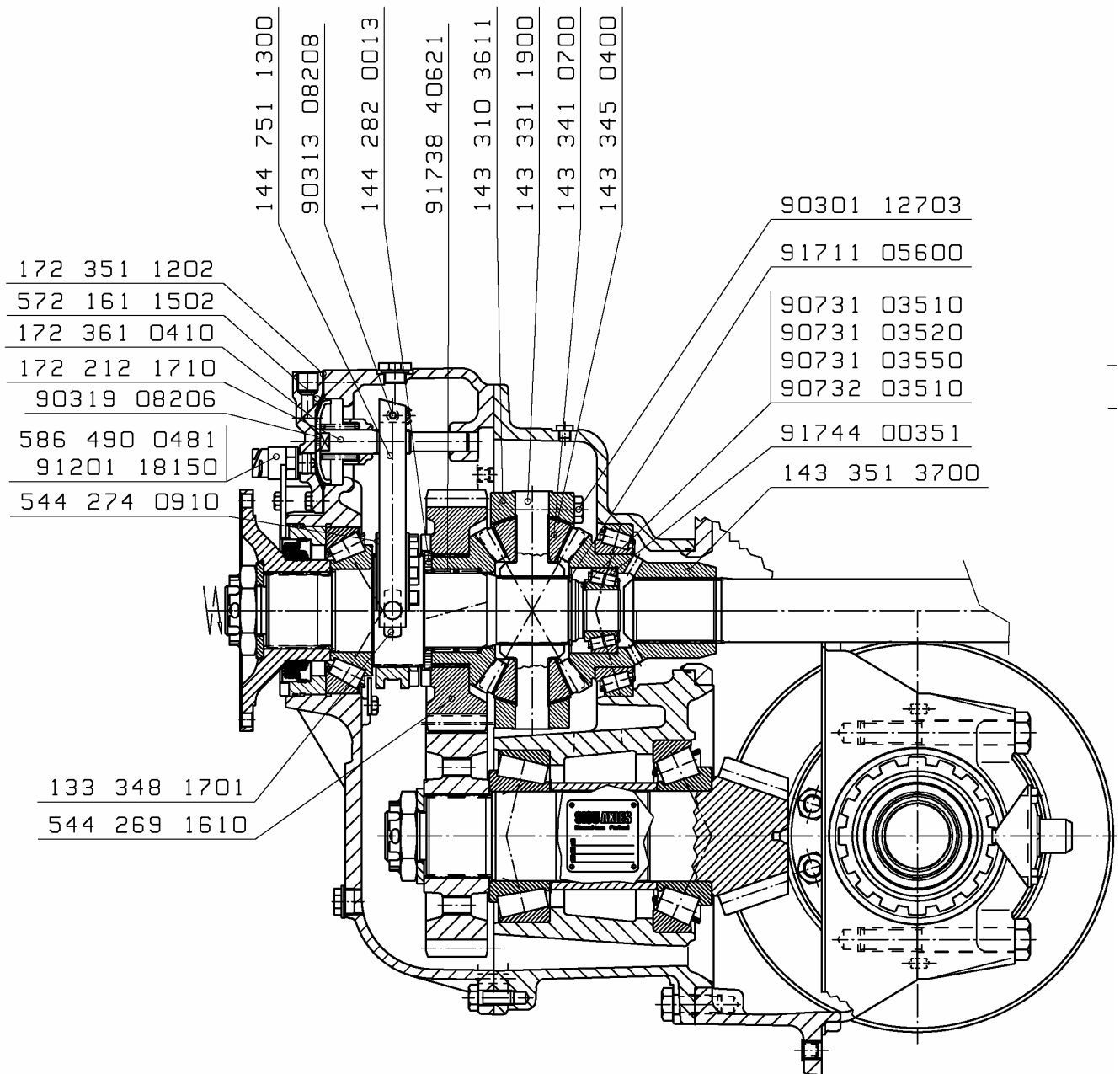

Picture 1. Items to be removed

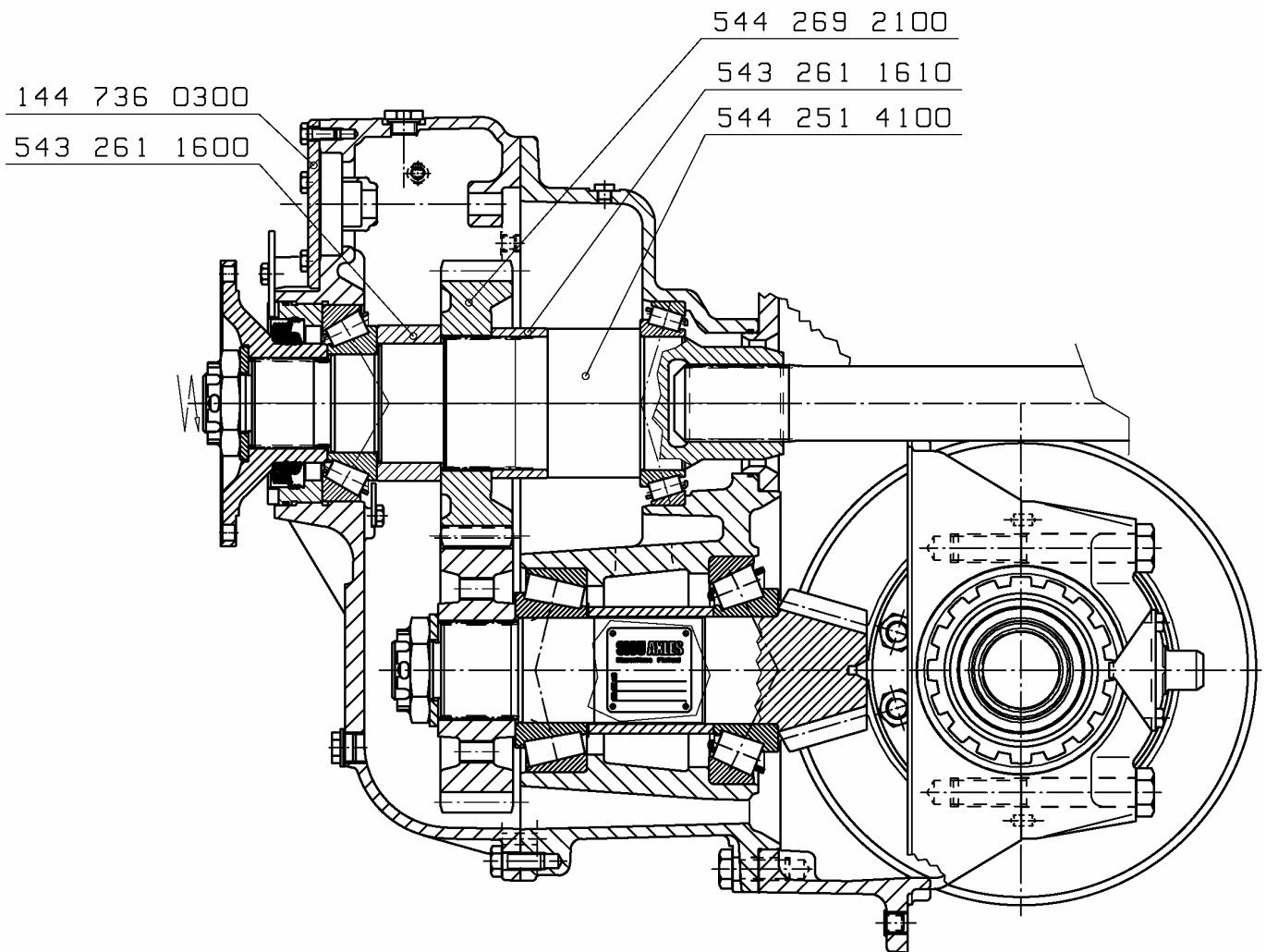

Picture 2. Items to be installed